



DIECI
AUSTRALIA

SAMSON | 70.10



SAMSON

UNMATCHED POWER FOR HEAVY DUTY PRECISION

The characteristics of Dieci products can be summarised in three concepts that have always been the hallmark of each machine: **technology, reliability** and **durability**.

We consistently enhance our machines by incorporating the best solutions derived from research, customer feedback, and practical experience. Our telehandlers are specifically designed to meet the diverse needs of Australia's various environments.

The **Samson** is a top-quality telehandler, categorised by its load capacity. Ideal for work environments where there is a need to handle large volumes and reduce work cycles. Maintenance is straightforward, with durable components and materials designed to last.

Great power, excellent handling, precision movement control, sound proofing for absolute comfort, three steering modes including 2WS, 4WS and crab steering, as well as the intelligently designed control layout, makes the Samson simple, intuitive and comfortable to use.

The Samson can be fitted with a full range of accessories, making it an **incredibly versatile** machine.

ABSOLUTE COMFORT: ITALIAN DESIGN AND STYLE

Dieci telehandlers have always been a combination of **comfort** and **functionality** which makes us stand out all over the world.

Advanced Telescopic Boom

Reinforced boom is made of high resistance steel with load sensing and flow sharing distributors that offer simultaneous movements for more efficient work.

4-in-1 Joystick

The boom can be fully operated by the hydraulic control distributor-single joystick with proportional and simultaneous controls which also incorporates FNR, for easier and more practical direction control.

Perfect Climate

Equipped with an integrated electric driver's window, standard heater and a semi-automatic air conditioning system with six outlet vents, this setup allows perfect air circulation inside the cabin for maximum operator comfort.

Powerful & Stable

Extremely rugged machine with exceptional loading capacities in all operating conditions, whether the boom is retracted or extended. Equipped with a transversal leveling device to keep the chassis in a horizontal position, even on uneven ground.

Maximum Safety

The ROPS-FOPS approved cab is designed with a safety cell to provide maximum safety to the operator at all times. Dieci telehandlers comply with AS1418.19 / 10896.1.

Deadman sensor, combined with operator presence sensor in the seat, prevents accidental operation.

The **Load Limiter Device** analyses vehicle stability in real time and inhibits any aggravating movements when the pre-set safety limits are reached.



Samson 70.10

9.65m
Max Reach

7,000kg
Max Capacity

125hp / 93kW
Nominal Power



Side Shift Carriage

Equipped with a side shift carriage, making repositioning and stacking loads tightly, an effortless task.

Single Compensation Cylinder

Patented by Dieci - is located inside the lifting ram, ensures that the load on the boom is balanced at all times, thereby improving durability.

Inching Pedal

An essential control that allows travel speed to momentarily slow down or come to a stop while still offering maximum power to boom functions to increase precision and productivity for delicate operations.

Hydrostatic Transmission

Complete with a servo controlled 2 speed gear box and constantly varying hydrostatic drive, which guarantees top-end speed and low-end torque.

Panoramic Views

The large, curved windows of the cab offer a complete 360° outside view with uninterrupted visibility.

134° Fork Swivelling Angle Rotation

Specially designed to increase the operating arc, which is particularly useful when unloading with the boom raised.

Reversible Fan

The engine cooling system utilises a reversible fan to blow any dust and fibres away from the radiator.

130L Hydraulic Flow Rate

The 130l/min hydraulic flow maximises manoeuvrability in all applications.

Comfort & Ease of Access

Spacious cab designed for operator comfort and ergonomics, adjustable steering wheel (height and depth), air suspension seat and storage compartments.

TECHNICAL DATA

PERFORMANCE

Maximum capacity	7,000 kg
Maximum lifting height	9.65 m
Maximum horizontal extension	5.40 m
Fork swiveling angle	134 °
Pull-out force	5,700 daN
Towing force	7,300 daN
Maximum climb angle	40 %
Unladen weight	12,100 kg
Maximum speed	40 km/h

ENGINE

Brand	FPT
Nominal power	125 hp / 93 kW (@ 2,200 rpm)
Operation	4-stroke / diesel
Injection	Mechanical direct
Number and arrangement of cylinders	4, vertical inline
Displacement	4,485 cm ³
Emission standard	Stage IIIA/Tier 3
Cooling	Liquid
Intake	Turbocharger after-cooler

TRANSMISSION

Type	Hydrostatic transmission with variable displacement pump
Hydraulic motor	Hydrostatic with continuous automatic adjustment
Reversal	Electro-hydraulic
Inching control	With hydraulic pedal for controlled forward movement
Gearbox	Servo-controlled 2-speed

HYDRAULIC SYSTEM

Hydraulic pump type	Gear pump for power steering and movements
Hydraulic pump capacity	130 l/min
Maximum operating pressure	26 MPa (3,771 psi)
Boom hydraulic sockets	With quick couplings
Distributor control	Joystick with integrated FNR (with deadman capacitive sensor)
Distributor type	Hydraulic distributor-single joystick with proportional and simultaneous controls

TANK CAPACITIES

Hydraulic tank	160 l
Diesel tank	125 l

DIFFERENTIAL AXLES

Steering axles	2 steering, with 4 epicycloidal reduction gears
Type of steering	4 wheels / transversal / 2 wheels
Service brake	Oil bath with servo brake on front and rear with double hydraulic system
Park brake	Negative actuation with electrical control

TYRES

Size	18x22.5"
------	----------

SAMSON 70.10

DIMENSIONS

A	420 mm
B	1,646 mm
C	2,950 mm
D	1,425 mm
F	4,955 mm
G	6,021 mm
H	2,490 mm
I	940 mm
L	1,920 mm
M	2,380 mm
O	4,730 mm
P	1,700 mm
Q	4,400 mm

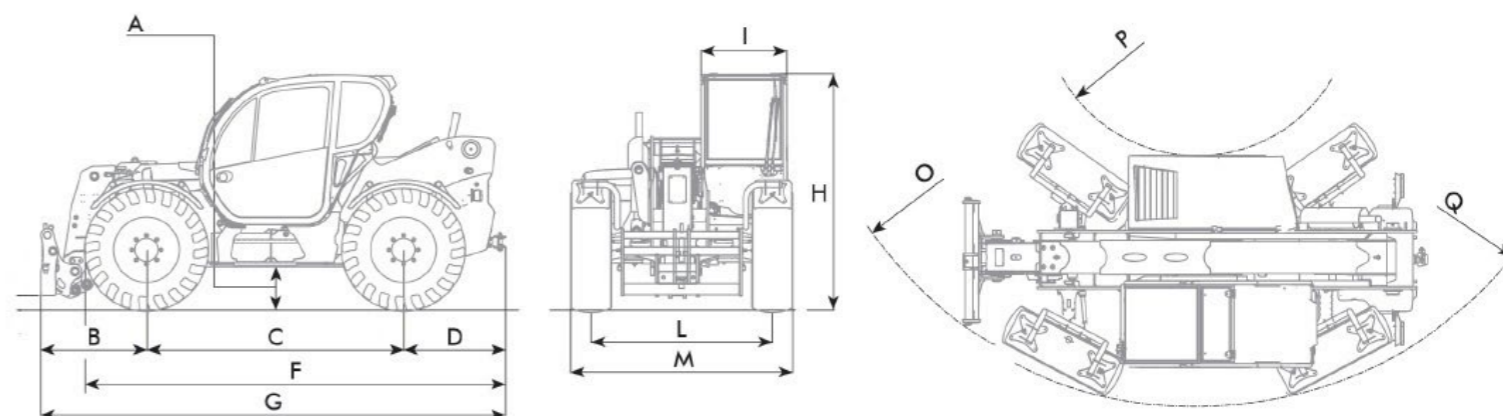

LOAD CHARTS

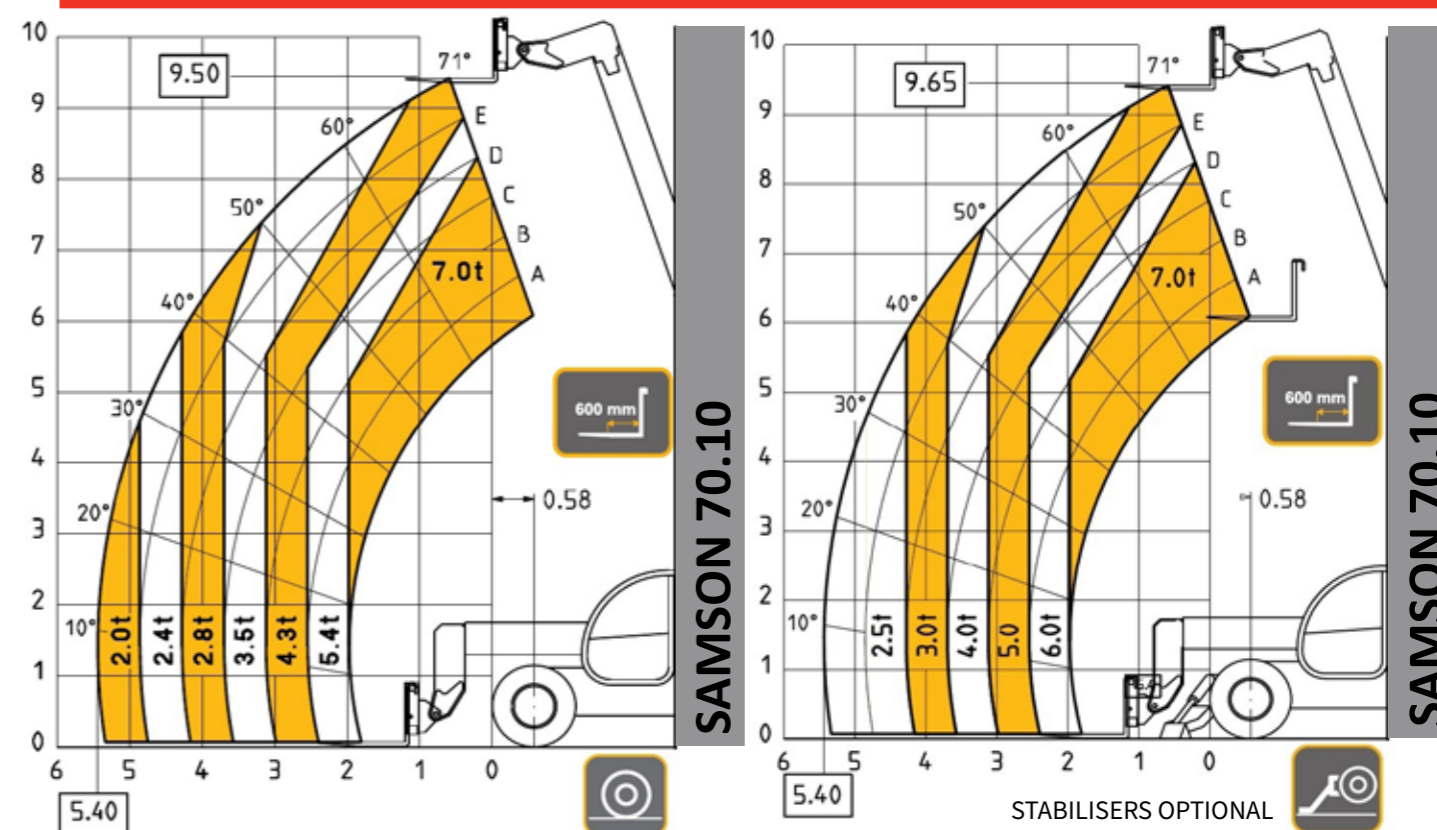



NEW SOUTH WALES

Sydney Branch
1/5 Melito Court,
Prestons, NSW 2170

WESTERN AUSTRALIA

Perth Branch
32 Allott Way,
Maddington, WA 6109

VICTORIA

Melbourne Branch
169 Studley Court,
Derrimut, VIC 3026

QUEENSLAND

Brisbane Branch
78-80 Platinum Street,
Crestmead, QLD 4132

Brisbane North Branch
69 Griffin Crescent,
Brendale, QLD 4500



www.dieciaustralia.com.au | ph: 1300 888 479 | sales@dieciaustralia.com.au

Distributed by Dieci Australia

Illustrations and photos show the standard international models and may or may not include optional equipment, accessories, customer installed or modified parts, optional parts and all standard equipment with some differences in colour and features. Machine specifications are subject to change without notice and additional load charts and machine or attachment specifications may be available on request. Please refer to the user and maintenance manuals located on Dieci Australia's website for correct machine and attachment operation.



Printed in Australia

Samson_0924