

**DIECI**  
AUSTRALIA

HERCULES | 120.10 | 190.10 | 210.10 | 230.10





## HERCULES A GIANT READY FOR ANYTHING

With the ever-changing needs of construction sites and a strong emphasis on reducing management costs and improving machine productivity, Dieci addresses these demands with a range of machines that advance the construction industry. They offer versatility, high performance, durability, reliability, intuitive operation, and unwavering safety.

The **Hercules** family, the strongest of the Dieci telehandlers, breaks all limits in terms of load capacity, reaching a maximum payload of up to 23 tonnes and a height of 10 metres. Strength, stability and robustness make this telescopic handler a true legend for heavy-duty work.

Recognised for their power, stability, and strength, the Hercules' offer optimal performance, extreme lifting abilities, precision movement control, soundproof comfort, three steering modes including 2WS, 4WS and crab steering, and straightforward maintenance with durable components, making them a true workhorse.

The Hercules range can be fitted with a **wide range of accessories** (winches, forks, buckets, EWP's, bale clamps, cylinder grabs, tyre handlers etc.) or tools for specific needs or requirements.

## ABSOLUTE COMFORT: ITALIAN DESIGN AND STYLE

Dieci telehandlers have always been a combination of **comfort** and **functionality** which makes us stand out all over the world.

### Manoeuvrable & Effective

Get great capacity, control and precision with the enhanced soft motion system, allowing proportional, predictable and over all accuracy of boom movement.

### Perfect Climate

Equipped with an openable driver's window, standard heater and a semi-automatic air conditioning system with six outlet vents, this setup allows perfect air circulation inside the cabin for maximum operator comfort.

### Proportional 4-in-1 Joystick

The boom can be fully operated by the hydraulic control distributor-single joystick with proportional and simultaneous controls for easier and more practical direction control.

### Strong & Stable

Maximum stability and traction with tyres suitable for all terrains - this range has 4 wheel steer and 4 wheel drive. They have 2 speed servo controlled reduction gearbox and a hydrostatic drive system, all this ensures precision movement, maximum speed and plenty of torque when required.

### Maximum Safety

The ROPS-FOPS approved cab is designed with a safety cell to provide maximum safety to the operator at all times. Dieci telehandlers comply with AS1418.19 / 10896.1.

The deadman switch on the joystick, combined with operator presence sensor in the seat, prevents accidental operation.

The **Load Limiter Device** analyses vehicle stability in real time and inhibits any aggravating movements when the pre-set safety limits are reached.



# Hercules 120.10

**9.5m**  
Max Reach

**12,000kg**  
Max Capacity

**139hp / 104kW**  
Nominal Power

## Load Sensing

Variable flow pump for boom movements and power steering.

## Single Compensation Cylinder

Patented by Dieci - is located inside the lifting ram, ensures that the load on the boom is balanced at all times, thereby improving durability.

## Inching Pedal

An essential control when movements must be slowed right down or stopped when precision in loading is required.

## 160 - 170L Hydraulic Flow Rate

The 160 - 170 l/min hydraulic flow maximises manoeuvrability in all applications.

## Wide Range of Attachments

A wide range of attachments available including man baskets, winches, hooks and jibs to cover all areas of the worksite.



## Panoramic Views

The large, curved windows of the cab offer a complete 360° outside view with uninterrupted visibility. Integrated LED work lights allow better visibility at night.

## 113° - 144° Fork Swivelling Angle Rotation

Specially designed to increase the operating arc, which is particularly useful when unloading with the boom raised.

## Hydrostatic Transmission

Complete with a servo controlled 2 speed gear box and constantly varying hydrostatic drive, which guarantees top-end speed and low end-torque.

## Comfort & Ease of Access

With soundproofing, an adjustable steering wheel (height and depth), storage compartments and various accessories such as the air suspension seat, enable operation in total comfort.

# Hercules 230.10

**10.2m**  
Max Reach

**23,000kg**  
Max Capacity

**173hp / 129kW**  
Nominal Power

# TECHNICAL DATA

PERFORMANCE	120.10	190.10	210.10	230.10
Max capacity	12,000 kg	19,000 kg	21,000 kg	23,000 kg
Max lifting height	9.5 m	10.2 m	10.2 m	10.2 m
Max horizontal extension	5.94 m	5.92 m	5.92 m	5.90 m
Fork swiveling angle	144 °	120 °	120 °	113 °
Pull-out force	9,700 daN	16,200 daN	18,900 daN	18,900 daN
Towing force	11,000 daN	19,500 daN	19,500 daN	19,500 daN
Max climb angle	36 %	36 %	36 %	35 %
Unladen weight	16,800 kg	24,500 kg	27,500 kg	29,000 kg
Max speed	35 km/h	23 km/h	23 km/h	22 km/h

ENGINE	120.10	190.10	210.10	230.10
Brand	FPT	FPT	FPT	FPT
Nominal power / @ rpm	139 hp / 104 kW @ 2,200	173 hp / 129 kW @ 2,200	173 hp / 129 kW @ 2,200	173 hp / 129 kW @ 2,200
Operation	4-stroke / diesel	4-stroke / diesel	4-stroke / diesel	4-stroke / diesel
Injection	Electronic, common rail	Electronic, common rail	Electronic, common rail	Electronic, common rail
Cylinders	4, vertical inline	6, vertical inline	6, vertical inline	6, vertical inline
Displacement	4,485 cm <sup>3</sup>	6,728 cm <sup>3</sup>	6,728 cm <sup>3</sup>	6,728 cm <sup>3</sup>
Emission standard	Stage IIIA/Tier 3	Stage IIIA/Tier 3	Stage IIIA/Tier 3	Stage IIIA/Tier 3
Cooling	Liquid	Liquid	Liquid	Liquid
Intake	Turbo compressor	Turbo compressor	Turbo compressor	Turbo compressor

TRANSMISSION	120.10	190.10	210.10	230.10
Type	Hydrostatic with variable displacement pump	Hydrostatic with variable displacement pump	Hydrostatic with variable displacement pump	Hydrostatic with variable displacement pump
Hydraulic motor	Hydrostatic with continuous automatic adjustment	Hydrostatic with continuous automatic adjustment	Hydrostatic with continuous automatic adjustment	Hydrostatic with continuous automatic adjustment
Reversal	Electro-hydraulic	Electro-hydraulic	Electro-hydraulic	Electro-hydraulic
Inching control	With hydraulic pedal for controlled forward movement	With hydraulic pedal for controlled forward movement	With hydraulic pedal for controlled forward movement	With hydraulic pedal for controlled forward movement
Gearbox	Servo-controlled 2-speed	Servo-controlled 2-speed	Servo-controlled 2-speed	Servo-controlled 2-speed

HYDRAULIC SYSTEM	120.10	190.10	210.10	230.10
Hydraulic pump type	"Load Sensing" variable flow pump for boom movements. Gear pump for power steering drive and for the cooling fan	"Load Sensing" variable flow pump for boom movements and power steering. Gear pump for cooling fan operation	"Load Sensing" variable flow pump for boom movements and power steering. Gear pump for cooling fan operation	"Load Sensing" variable flow pump for boom movements and power steering. Gear pump for cooling fan operation
Hydraulic pump capacity	160 l/min	170 l/min	170 l/min	170 l/min
Max operating pressure	30 MPa (4,351 psi)	35 MPa (5,076 psi)	35 MPa (5,076 psi)	35 MPa (5,076 psi)
Boom hydraulic sockets	With flat face quick couplings	With flat face quick couplings	With flat face quick couplings	With flat face quick couplings
Distributor control	Proportional 4-in-1 joystick	Proportional 4-in-1 joystick	Proportional 4-in-1 joystick	Proportional 4-in-1 joystick
Distributor type	"Flow Sharing" servo controlled hydraulic	"Flow Sharing" servo controlled hydraulic	"Flow Sharing" servo controlled hydraulic	"Flow Sharing" servo controlled hydraulic

TANK CAPACITIES	120.10	190.10	210.10	230.10
Hydraulic tank	246 l	246 l	246 l	246 l
Diesel tank	207 l	207 l	207 l	207 l

TYRES	120.10	190.10	210.10	230.10
Size	17.5x25"	20.5x25"	23.5x25"	26.5x25"

# HERCULES

DIFFERENTIAL AXLES	120.10	190.10	210.10	230.10
Steering axles	2 steering, with 4 epicycloidal reduction gears	2 steering, with 4 epicycloidal reduction gears	2 steering, with 4 epicycloidal reduction gears	2 steering, with 4 epicycloidal reduction gears
Type of steering	4 wheels / transversal / 2 wheels	4 wheels / transversal / 2 wheels	4 wheels / transversal / 2 wheels	4 wheels / transversal / 2 wheels
Service brake	Oil bath with servo brake on front and rear axle with double hydraulic system	Oil bath with servo brake on front and rear axle with double hydraulic system	Oil bath with servo brake on front and rear axle with double hydraulic system	Oil bath with servo brake on front and rear axle with double hydraulic system
Park brake	Negative actuation with electrical control	Negative actuation with electrical control	Negative actuation with electrical control	Negative actuation with electrical control

## LOAD CHARTS

Hercules range load charts showing hydraulic fork positioner with 1200mm LC. Alternative load charts available on request

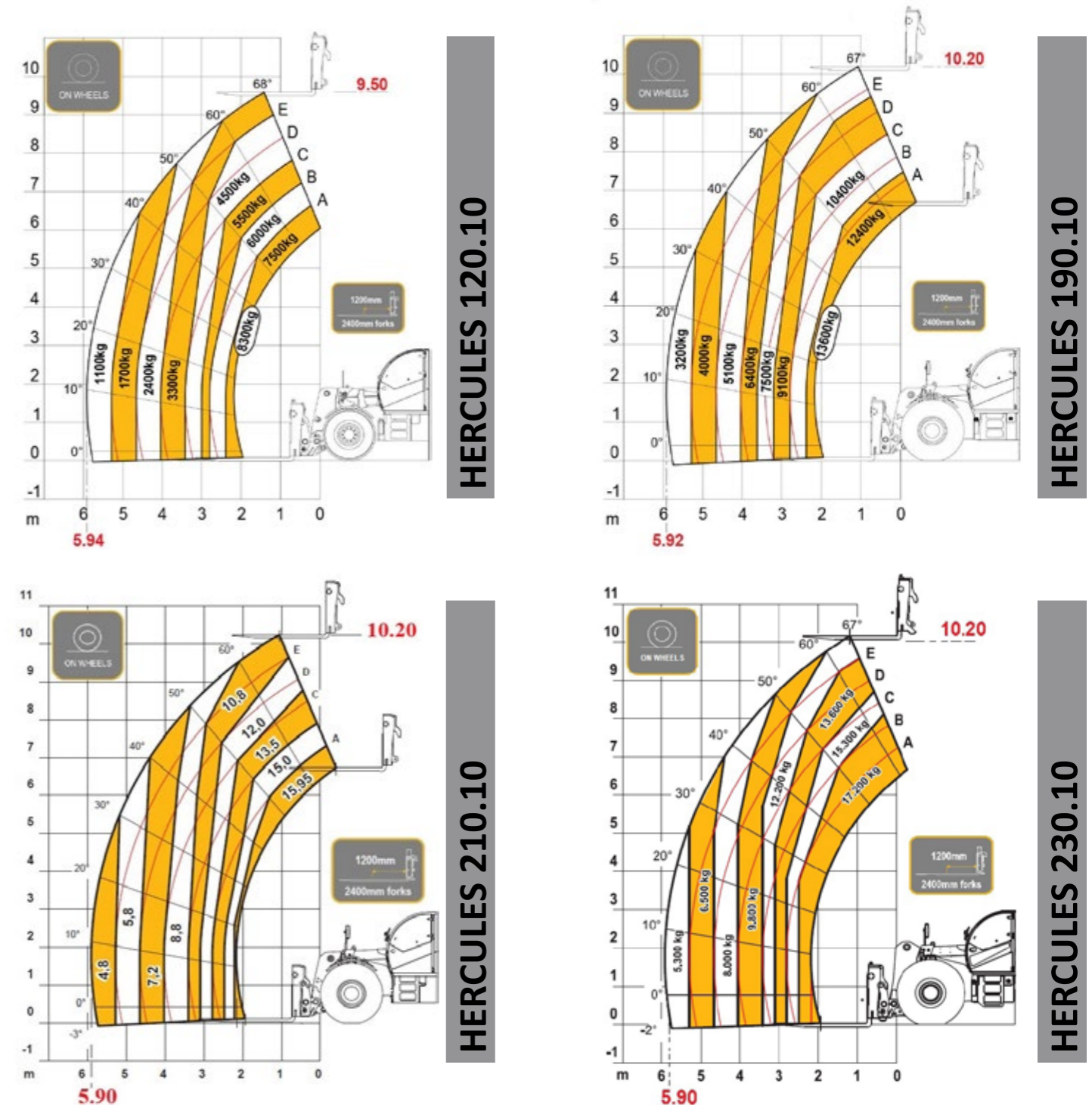

DIMENSIONS	120.10	190.10	210.10	230.10
A	490 mm	530 mm	530 mm	470 mm
B	1,270 mm	1,320 mm	1,320 mm	1,320 mm
C	3,300 mm	3,850 mm	3,850 mm	3,850 mm
D	1,480 mm	1,630 mm	1,630 mm	1,630 mm
G	6,050 mm	6,800 mm	6,800 mm	6,800 mm
H	2,890 mm	2,930 mm	2,930 mm	2,980 mm
I	980 mm	980 mm	980 mm	980 mm
L	1,975 mm	2,015 mm	2,045 mm	2,180 mm
M	2,420 mm	2,600 mm	2,700 mm	2,880 mm
P	1,480 mm	3,530 mm	3,530 mm	3,530 mm
Q	4,350 mm	6,500 mm	6,500 mm	6,530 mm
R	4,580 mm	6,500 mm	6,500 mm	6,750 mm

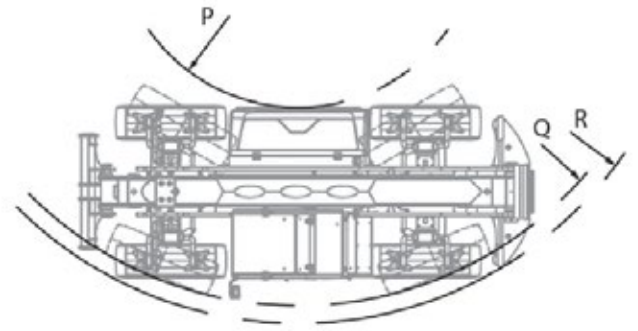
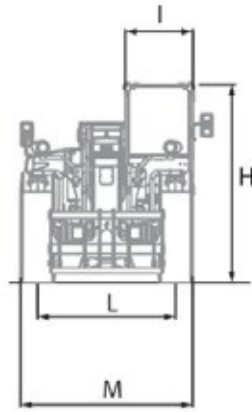
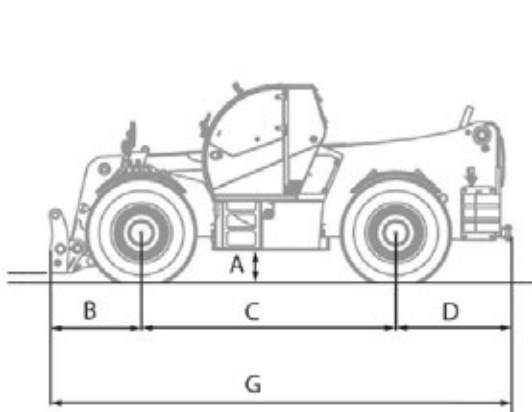

#### NEW SOUTH WALES

Sydney Branch  
1/5 Melito Court,  
Prestons, NSW 2170

#### VICTORIA

Melbourne Branch  
169 Studley Court,  
Derrimut, VIC 3026

#### WESTERN AUSTRALIA

Perth Branch  
32 Allott Way,  
Maddington, WA 6109

#### QUEENSLAND

Brisbane Branch  
78-80 Platinum Street,  
Crestmead, QLD 4132

Brisbane North Branch  
69 Griffin Crescent,  
Brendale, QLD 4500

[www.dieciaustralia.com.au](http://www.dieciaustralia.com.au) | ph: 1300 888 479 | [sales@dieciaustralia.com.au](mailto:sales@dieciaustralia.com.au)

Distributed by Dieci Australia

Illustrations and photos show the standard international models and may or may not include optional equipment, accessories, customer installed or modified parts, optional parts and all standard equipment with some differences in colour and features. Machine specifications are subject to change without notice and additional load charts and machine or attachment specifications may be available on request. Please refer to the user and maintenance manuals located on Dieci Australia's website for correct machine and attachment operation.



Printed in Australia

Hercules\_0924