



DIECI
AUSTRALIA

APOLLO | 25.6



APOLLO BIG PERFORMANCE FOR SMALL SPACES

The characteristics of Dieci products can be summarised in three concepts that have always been the hallmark of each machine: **technology, reliability and durability.**

We consistently enhance our machines by incorporating the best solutions derived from research, customer feedback, and practical experience. Our telehandlers are specifically designed to meet the diverse needs of Australia's various environments.

The **Apollo** is designed to be your workhorse in restricted spaces due to its compact size, allowing it to fit into tight and difficult spaces. The high strength of the boom makes it possible to handle loads at great heights.

Great power, excellent handling, precision movement control, sound proofing for absolute comfort, three steering modes including 2WS, 4WS and crab steering, as well as the intelligently designed control layout, makes the Apollo simple, intuitive and comfortable to use.

The **Apollo** can be fitted with a full range of accessories, making it an incredibly versatile machine.

ABSOLUTE COMFORT: ITALIAN DESIGN AND STYLE

Dieci telehandlers have always been a combination of **comfort** and **functionality** which makes us stand out all over the world.

Top Level Performance

Superior performance, thanks to the boom which achieves the perfect balance between size and strength. Incredibly responsive and totally free of any uncontrolled movement thanks to the central position of the boom.

Unparalleled Manoeuvrability

One of the most agile Dieci telehandlers, the Apollo upholds the exceptional comfort and versatility of the entire range. The high-efficiency steering system guarantees a light and responsive feel, even under heavy load conditions.

Hydraulic Flow Share

The operator can control multiple joystick functions at the same time for maximum efficiency including boom up/down, boom in/out and fork swivel.

Maximum Safety

The ROPS-FOPS approved cab is designed with a safety cell to provide maximum safety to the operator at all times. Dieci telehandlers comply with AS1418.19 / 10896.1.

Deadman sensor, combined with the operator presence sensor in the seat, prevents accidental operation.

The **Load Limiter Device** analyses vehicle stability in real time and inhibits any aggravating movements when the pre-set safety limits are reached.



Apollo 25.6

5.78m
Max Reach

2,500kg
Max Capacity

74hp / 55.4kW
Nominal Power

Single Compensation Cylinder

Patented by Dieci - is located inside the lifting ram, ensures that the load on the boom is balanced at all times, thereby improving durability.

Inching Pedal

An essential control that allows travel speed to momentarily slow down or come to a stop while still offering maximum power to boom functions to increase precision and productivity for delicate operations.

80L Hydraulic Flow Rate

The 80lpm hydraulic flow maximises manoeuvrability in all applications.

129° Fork Swivelling Angle Rotation

Specially designed to increase the operating arc, which is particularly useful when unloading with the boom raised.

Total Visibility

The wide windows of the cab offer a complete 360° outside view.

Perfect Climate

Equipped with a standard heater and a semi-automatic air conditioning system with five outlet vents, this setup allows perfect air circulation inside the cabin for maximum operator comfort.

4-in-1 Joystick

The boom can be fully operated by the hydraulic control distributor-single joystick with proportional and simultaneous controls which also incorporates FNR, for easier and more practical direction control.

Sturdy Chassis

Ergonomically designed cab with innovative DSCS door made from composite material with high thermal and acoustic insulation properties for improved operator comfort.

Comfort & Ease of Access

Spacious cab designed for operator comfort and ergonomics. Compact design for access into confined areas, adjustable steering wheel (height and depth), air suspension seat and storage compartments.



TECHNICAL DATA

PERFORMANCE

Maximum capacity	2,500 kg
Maximum lifting height	5.78 m
Maximum horizontal extension	3.35 m
Fork swiveling angle	129°
Pull-out force	7,600 daN
Towing force	4,400 daN
Maximum climb angle	40 %
Unladen weight	5,100 kg
Maximum speed	30 km/h

ENGINE

Brand	Kubota
Nominal power	74 hp / 55.4 kW (@ 2,600 rpm)
Operation	4-stroke / diesel
Injection	Mechanical
Number and arrangement of cylinders	4, vertical inline
Displacement	3,331 cm ³
Emission standard	Stage IIIA/Tier 3
Cooling	Liquid
Intake	Turbo compressor

TRANSMISSION

Type	Single speed hydrostatic transmission with variable displacement pump
Hydraulic motor	Hydrostatic with continuous automatic adjustment
Reversal	Electro-hydraulic
Inching control	With hydraulic pedal for controlled forward movement

HYDRAULIC SYSTEM

Hydraulic pump type	Gear pump for power steering and movements
Hydraulic pump capacity	80 l/min
Maximum operating pressure	23 MPa (3,336 psi)
Boom hydraulic sockets	With quick couplings
Distributor control	4 in 1 proportional joystick
Distributor type	Single lever hydraulic proportional

TANK CAPACITIES

Hydraulic tank	70 l
Diesel tank	80 l

DIFFERENTIAL AXLES

Steering axles	2 steering, with 4 epicycloidal reduction gears
Type of steering	4 wheels / transversal / 2 wheels
Service brake	Oil bath on front axle
Park brake	Negative actuation with electrical control

TYRES

Size	12x16.5"
------	----------

APOLLO 25.6

DIMENSIONS

A	270 mm
B	985 mm
C	2,350 mm
D	765 mm
F	3,535 mm
G	4,125 mm
H	1,950 mm
I	1,850 mm
L	1,500 mm
M	1,850 mm
P	1,460 mm
Q	3,555 mm
S	1,433 mm

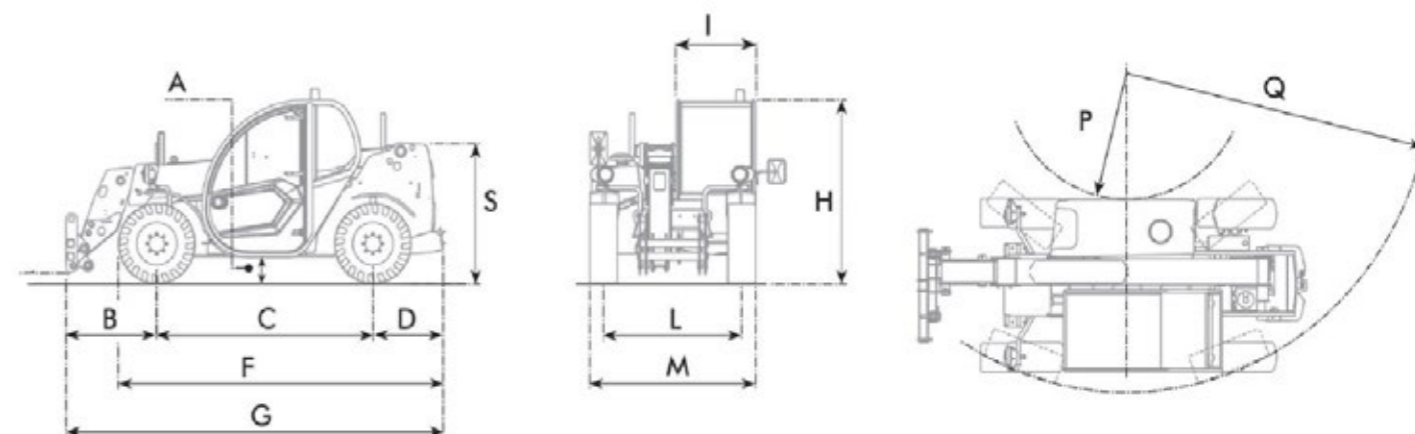

LOAD CHART

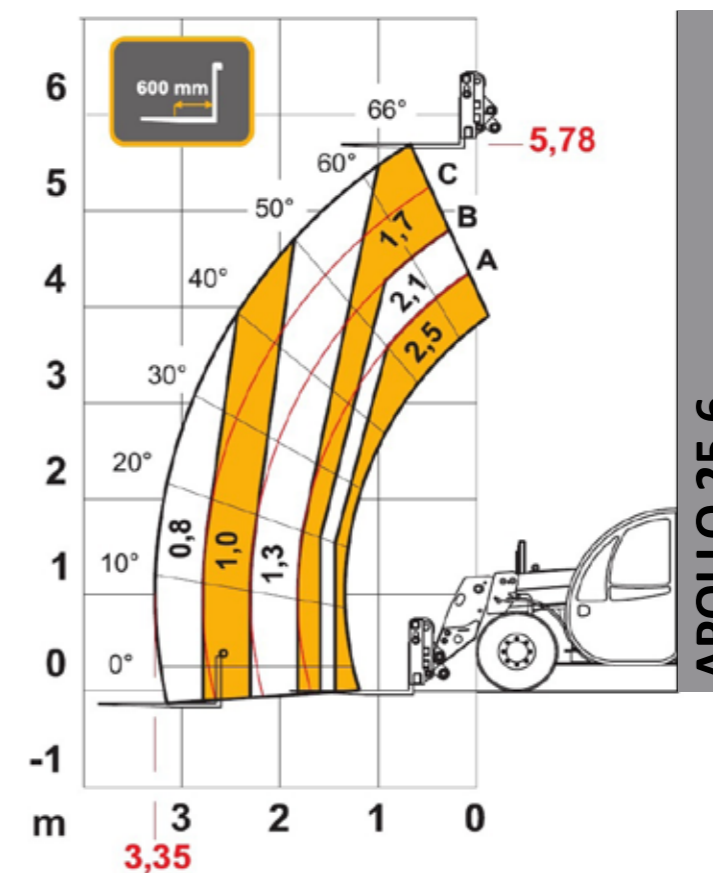



NEW SOUTH WALES

Sydney Branch
1/5 Melito Court,
Prestons, NSW 2170

WESTERN AUSTRALIA

Perth Branch
32 Allott Way,
Maddington, WA 6109

VICTORIA

Melbourne Branch
169 Studley Court,
Derrimut, VIC 3026

QUEENSLAND

Brisbane Branch
78-80 Platinum Street,
Crestmead, QLD 4132

Brisbane North Branch
69 Griffin Crescent,
Brendale, QLD 4500



www.dieciaustralia.com.au | ph: 1300 888 479 | sales@dieciaustralia.com.au

Distributed by Dieci Australia

Illustrations and photos show the standard international models and may or may not include optional equipment, accessories, customer installed or modified parts, optional parts and all standard equipment with some differences in colour and features. Machine specifications are subject to change without notice and additional load charts and machine or attachment specifications may be available on request. Please refer to the user and maintenance manuals located on Dieci Australia's website for correct machine and attachment operation.



Printed in Australia

Apollo_0924